

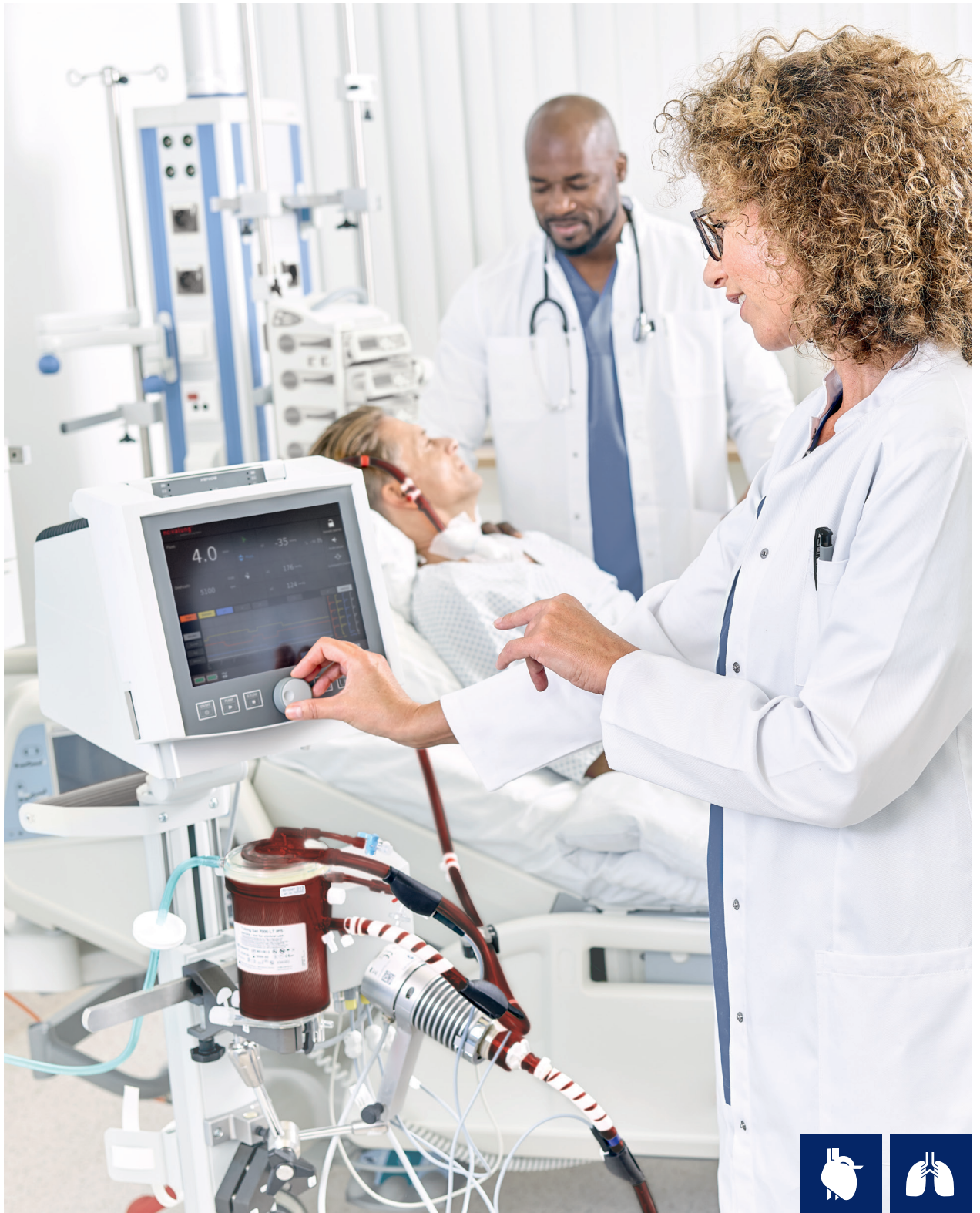

**FRESENIUS
MEDICAL CARE**



Critical Care



Xenios Console

Heart & Lung Therapies

A multifunctional system

Xenios offers products for the treatment for those suffering from cardiac and pulmonary insufficiency. Dedicated technology combines both heart and lung support in one single platform. Physicians and caregivers benefit from a technology platform for extracorporeal organ support – From effective CO₂ removal to full oxygenation^[1,2]. A rotary knob, buttons and a touchscreen can be used to navigate and monitor the therapy.

Broad spectrum of treatment options in both, heart and lung support

- Treatments for heart and lung support on one single platform
- For ECMO treatments with Advanced Mode applicable from neonates up to adults
- From partial CO₂ removal to full oxygenation^[1,2]
- VV, VA ECMO applications
 - ✓ ICU
 - ✓ Operating room
 - ✓ Cardiac catheterization lab

Ease of use features

- Therapy-driven interface
- Variable options for operation via touchscreen, buttons and rotary knob

Safety features

- Integrated Pressure Sensors (IPS) in our disposables
- Dual power: AC power and battery pack
- Alarm history on screen
- To activate / deactivate the pump switch to zero flow mode



The technological basis: A modular system - versatile in application

Xenios offers various trolleys and holder for different areas of application.

Xenios trolley N
for Intensive care unit

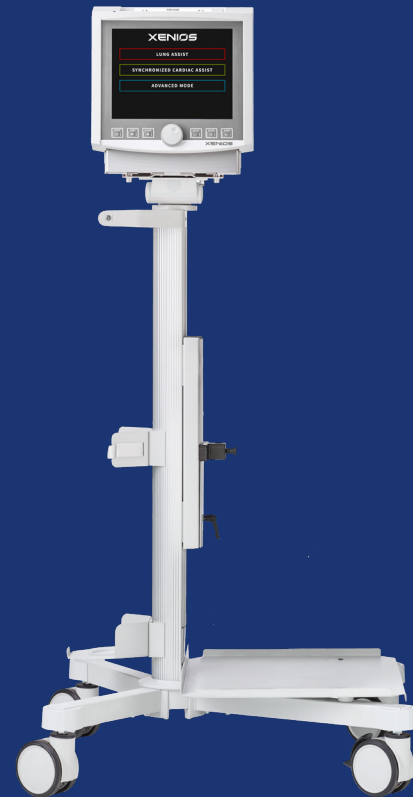

Xenios console



Xenios trolley M
for operating room and cath lab



MultiSupport GROUND

The MultiSupport GROUND (MSG) is a system consisting of different components, designed to enable inter-hospital transport of severely ill patients undergoing life-saving extracorporeal heart and lung support.



Compact holder (here with iLA membrane lung)

When the console is used without the trolley (e.g. for intra-hospital transport) the compact holder can be attached to the back of the console. In this setup, the system can also be used as a table unit.



Three treatment profiles provide a broad spectrum of extracorporeal support

Three treatment profiles take into account various usage scenarios and user requirements. "Lung Assist" is primarily used for ECCO₂R or respiratory ECMO treatments. The "Synchronized Cardiac Assist" mode is used for direct cardiac support and enables ECG-triggered pulsatility. The Advanced Mode enables cardiopulmonary support and is mainly used for cardiopulmonary ECMO therapy.

The therapy data can be sent directly to an external monitoring system*. Parameters such as blood flow, the speed of the pump head, pressure and temperature as well as alarms on the console are transferred directly to the patient monitor.

Lung Assist Lung support

ECCO₂R and Respiratory ECMO

- Intensive care unit
- Thoracic surgery

Synchronized Cardiac Assist Cardiovascular support

Synchronized Cardiac Support

- Cardiac surgical interventions
- Cardiac catheterization laboratory

Advanced Mode Cardiopulmonary organ support

Cardiopulmonary ECMO

- Cardiac surgery
- Cardiac catheterization laboratory
- Intensive care unit

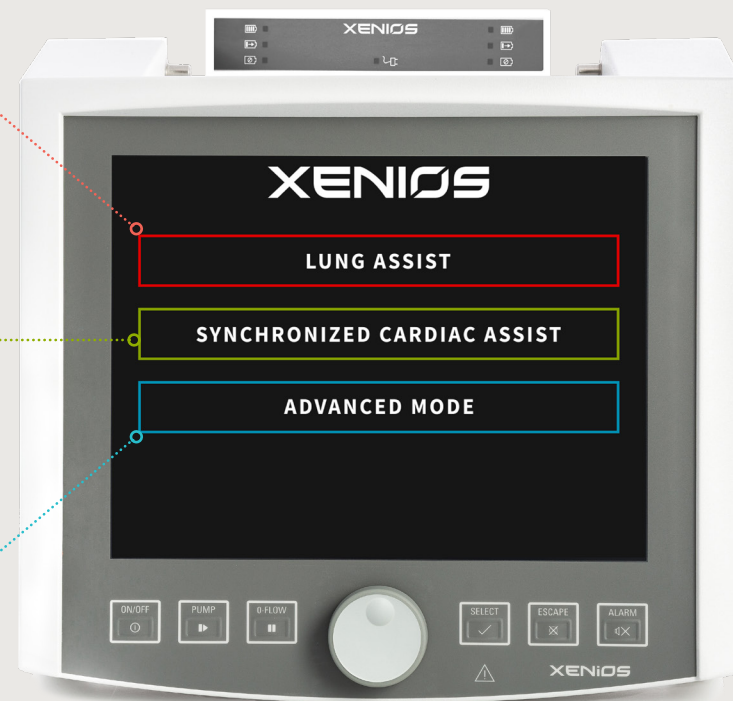

* for compatible systems please refer to your local sales representative

Various components make the console platform ready for use



Pump technology

- Diagonal pump, with up to 8 l/min of flow
- Adjustments of flow rate down to 0.1 l/min
 - Steps for 1/4" = 50 rpm
 - Steps for 3/8" = 100 rpm
- High-tech ceramic mount and magnetic coupling
- Sophisticated pump technology that may reduce turbulent flow and dead spaces as shown in a computational study compared to similar devices^[3]
- ECG-triggered pulsatile flow
- P1-limiter monitoring, zero flow mode

Patient kits

- The Xenios platform works with a range of various patient kits
- For up to 29 days of application period

Gas blender

- The Xenios platform can also be complemented by a gasblender



DP3 pump heads

- 1/4" with up to 2.4 l/min blood flow
- 3/8" with up to 8 l/min blood flow



DP3 pump drive

- Speed range from 0–10.000 rpm (rounds/minute)

Safety features for your treatments

Backup system

In challenging therapy situations the treatment can be continued via the battery-driven backup system:

Second backup pump drive

- Hot-swappable backup batteries for operation without external power supply
- No hand crank needed

Xenios console

- Zero flow function – flow stops when air bubbles are detected – whilst slow running pump counterbalances possible backflow
- Flow control for constant blood flow, e.g. for constant gas exchange level
- Automatic backflow compensation (especially for VA application)
- P1 limiter* can help to prevent excessive negative suction pressures, which can contribute to hemolysis^[4]

* The P1 limiter should not be used in Synchronized Cardiac Assist mode



Patient kits

Integrated Pressure Sensors – IPS*

- No interruption of the tubing system allowing undisturbed blood flow
- Pressure measurement without blood contact eliminates the risk of air aspiration
- No calibration during therapy necessary
- Design of the IPS sensors makes regular rinsing unnecessary and thus avoids hemodilution



* not available in all patient kits. For more information please refer to your local sales representative

Data Management



External Monitoring
Interface for therapy data to ICU monitors

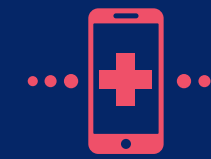

Nurse Call System
Interface for alarm activation of internal intensive care unit nurse call system



USB
Anonymous logfiles can be transferred directly to a USB device

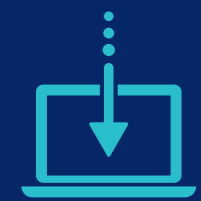

PDMS Data Interface
Retrievable data protocol for a patient-related electronic documentation system



By Your Side

We accompany excellent use of our technology and implementation of our therapies with individual support and application-oriented services.

Clinical Support



Our console is always accompanied by comprehensive support from our **local Clinical Support** teams. Each of our application specialists has many years of experience in the field. They provide you with on-site or virtual based support: comprising training and help in implementing our technology in your clinical day-to-day business. This includes also local support hotlines.

Technical Service



Our Technical Service is available for you to answer all your technical questions you may have in and around the Xenios platform. This service is also your contact for questions regarding the maintenance or repair of your Xenios devices. You can contact our technical service via email or our service hotline.

Education and Training



Xenios Campus - our e-learning platform for education, information and training - is putting the emphasis on blended learning. We know the value of having the right knowledge. That's why we offer you diverse study modules and videos that enable you to pursue individual advanced training in your specific areas of interest.

References

- 1 Redwan B. et al., (2015) Intraoperative veno-venous extracorporeal lung support in thoracic surgery: a single-centre experience. *Interact Cardiovasc Thorac Surg*: ivv253 [141]
- 2 Braune S. et al., (2016) The feasibility and safety of extracorporeal carbon dioxide removal to avoid intubation in patients with COPD unresponsive to noninvasive ventilation for acute hypercapnic respiratory failure (ECLAIR study): multicentre case-control study. *Intensive Care Med* 42(9): 1437–1444 [117]
- 3 Gross-Hardt S. et al., (2019) Low-flow assessment of current ECMO/ ECCO(2)R rotary blood pumps and the potential effect on hemocompatibility.
- 4 Excessive negative suction pressures, known to contribute to hemolysis" Toomasian J. and Bartlett R. (2011) Hemolysis and ECMO pumps in the 21st Century. *Perfusion* 26(1): 5–6